



# Australian Compliance Laboratory

## Test Report

**Report ID ACL1349 issued 25 March 2022**

Testing a weldless steel guardrail assembly to the requirements of AS 1657 (2018),  
Appendix B.



Australian Compliance Laboratory is accredited for compliance with ISO/IEC 17025 – Testing. NATA accreditation number 20358. NATA refers to the National Association of Testing Authorities. NATA is a signatory to the ILAC Mutual Recognition Agreement for the mutual recognition of the equivalence of testing, medical testing, calibration, inspection, proficiency testing scheme providers and reference material producers reports and certificates.

**Client details:** Barrier Group Pty. Ltd.

58-62 Separation Street, North Geelong, VIC 3215

**Packaging tested:** Weldless steel safety barrier fence assembly. Assembled with pillars and two-tier rails. The guardrail is secured together using cast steel joiners that incorporate grub screws.

**Job notes**

1. **Guardrail sample.** The sample components were selected and supplied by the client. The components formed two sections of guardrail with incorporated three posts and four rails.
2. **Sample assembly.** The sample was assembled by ACL to the client's instructions, whereby the grub screws were torqued to 60Nm. The concrete slab for mounting the sample was cast by ACL two weeks prior to testing (9 March 2022). Refer to Appendix B for the guardrail geometry and Appendix C for the concrete slab geometry.

**TESTING OF GUARDRAIL ING COMPRISING RAILS AND POSTS**

**Test method:** AS 1657 (2018), Appendix B: Fixed platforms, walkways, stairways and ladders – Design, construction and installation. **Result criteria:** AS 1657 (2018), Appendix B5. **Testing location:** The tests were conducted at the laboratory plant.

The guardrail was assembled as per the client's instructions in a concrete slab. The rail was then preloaded to 50% of the target test load for 1-minute before being subjected to each of the tests. The force was then gradually increased to the target test load and held for 1-minute, and then the deflection measured. The force was then removed for 2-minutes and then the residual deflection was measured. The test was conducted at ambient conditions. The same rail was used for all the tests in the order that they're presented.

Test name	Target test load	Actual test load	Result		
			Deflection at load	Residual deflection	Determination
Horizontal point load at top of post (B4.5)	600N	608.3N	7.0mm	1.5mm	Pass
Horizontal point load on top rail (B4.6)	600N	604.8N	7.5mm	0.5mm	Pass
Vertical point load on top rail (B4.7)	600N	602.8N	3.0mm	0.5mm	Pass
Horizontal UDL on top rail (B4.8)	721N	726.9N	5.5mm	1.0mm	Pass
Horizontal point load at top of post (B4.9)	1200N	1202.6N	16.5mm	2.5mm	Pass
Horizontal UDL on top rail (B4.10)	1442.1N	1449.4N	18.5mm	3.0mm	Pass
Horizontal point load on top rail (B4.11)	1200N	1207.6N	17.5mm	0.5mm	Pass

**Calculations:**

$Test\ load = Pressure \times Area$

$Uniform\ distributed\ load\ (UDL)(N) = 2.06m\ rail\ length \times 350N/m = 721N$

$ULD\ tests,\ pneumatic\ ram\ spacing = 2.06m\ rail\ length \div 4 = 515mm$

**Notes:**

1. No permanent deflection was observed.
2. The test load was applied using pneumatic rams and the force was measured using a pressure transducer.
3. The uniform distributed load (UDL) tests were conducted using three pneumatic rams with a spacing of 515mm.

**Instrumentation ID:** PRES.01, RULE.04

**Authorising signatory:**



Harley Donkers, Senior Signatory Officer

Appendix A – Product photographs



Appendix B – Product sketch

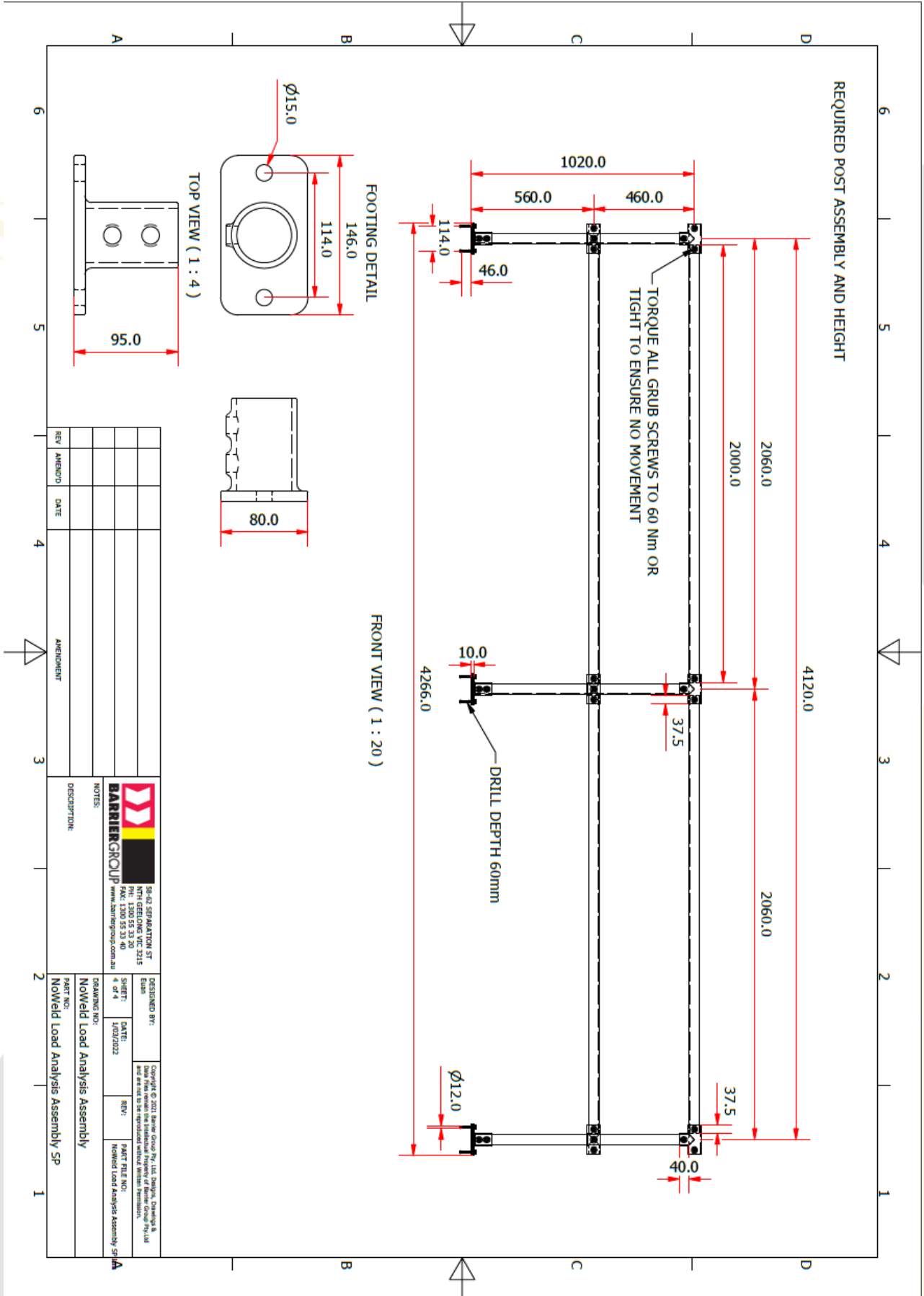

Appendix C – Concrete mould sketch

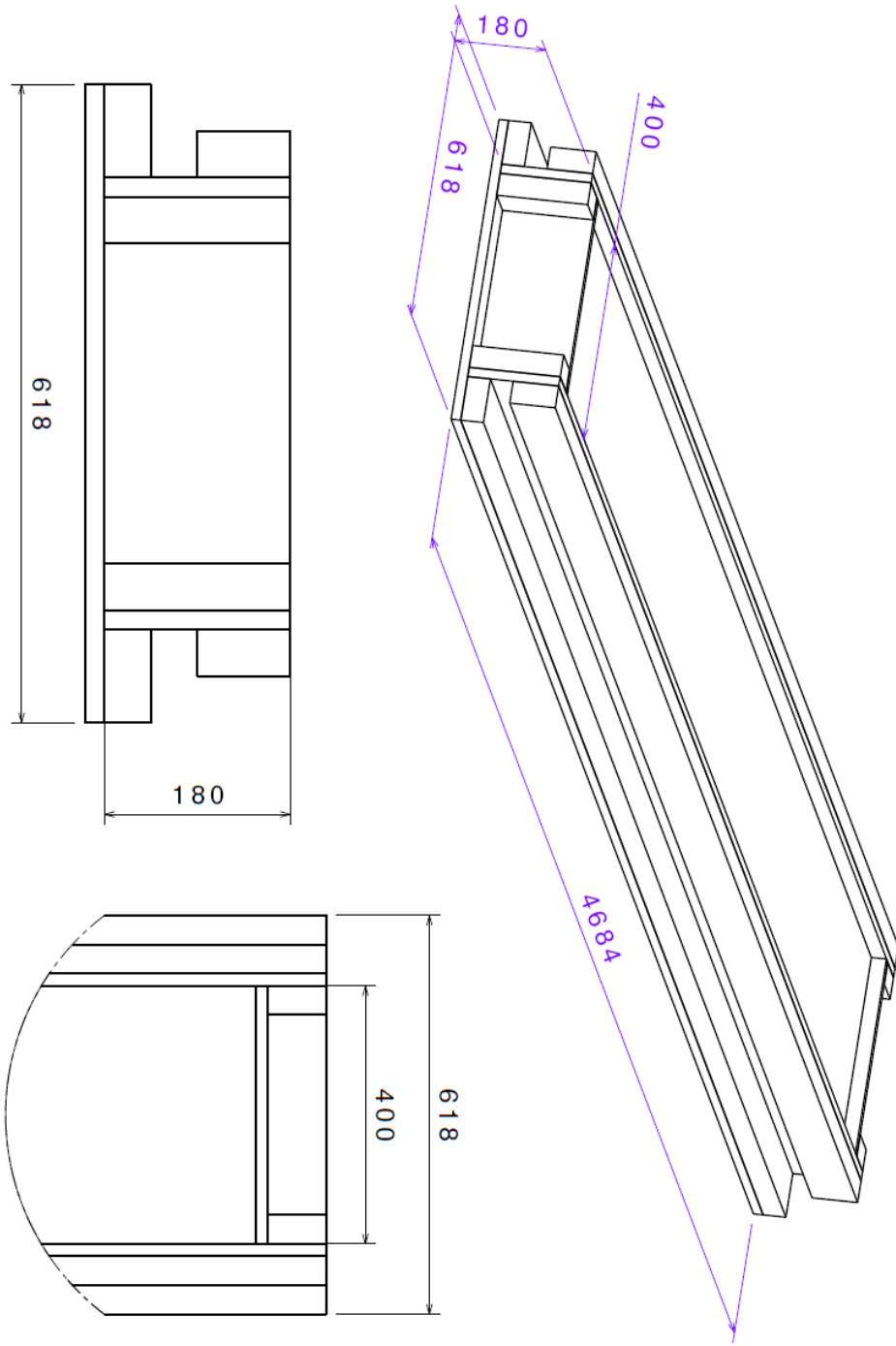

Appendix D – Uniform distributed load picture

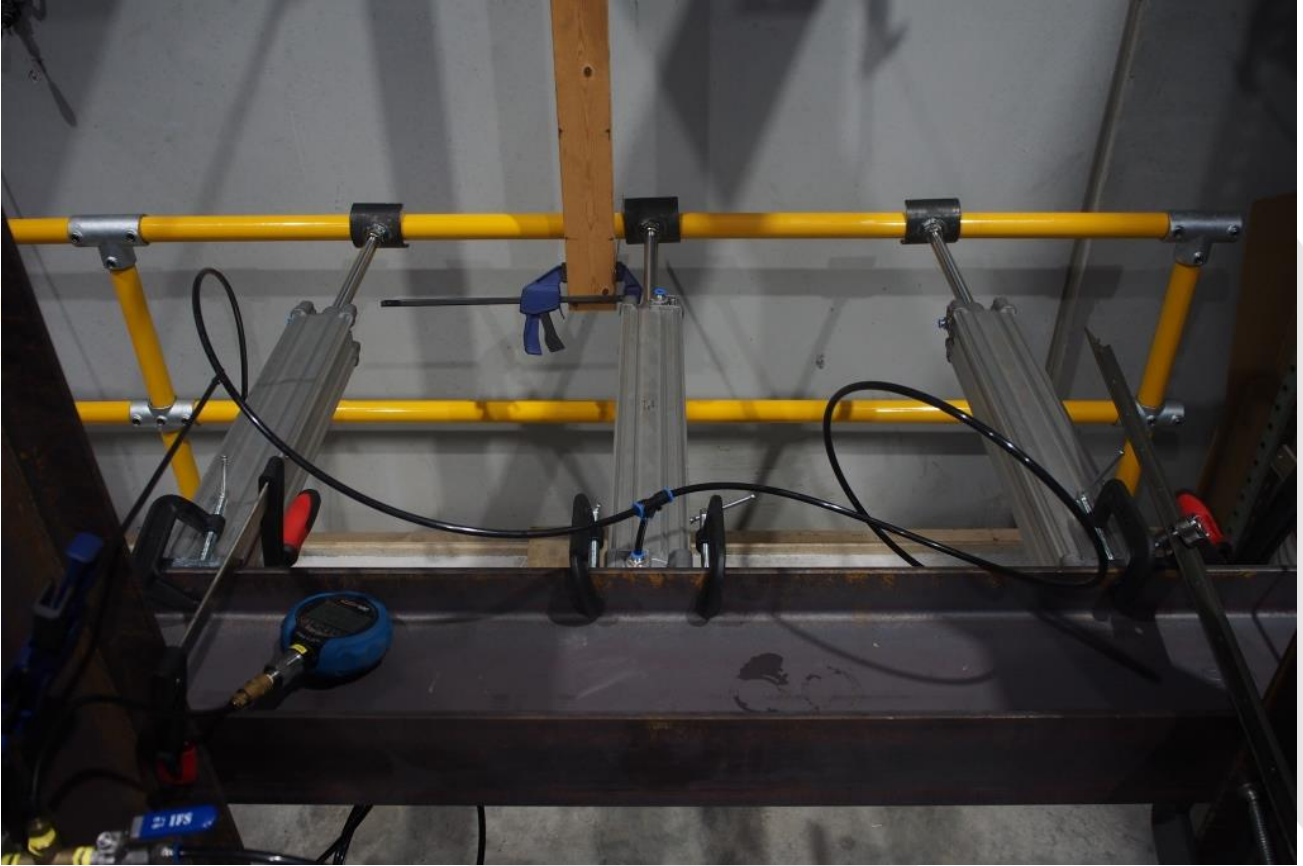

**Report information**

This test report shall not be reproduced except in full. The results of the tests and measurements included in this document are traceable to Australian/national standards.

The packagings tested in this report were prepared as if for transport. The results of the reported performance tests only relate to those packagings tested. Thus, the use of other packaging methods or components may render the testing in this report invalid.

The information and opinions in this report have been compiled by ACL and are believed to be accurate at the time of issue. However, this report may be changed with written notice.

\* Indicates details that have been nominated by the client for which they are responsible for.

**Confidential information**

This report is subject to the confidential information clauses within ACL's Terms of Service. This report is confidential information between ACL and the client. However, the client may use it in whatever manner they please.

This report may be shared between ACL staff for work purposes only. All ACL staff have signed a Confidentiality and Impartiality Statement which is available upon request.

**ACL information**

Australian Compliance Laboratory Pty. Ltd. – 99 620 633 598  
25/89 Boundary Road (Optic Way), Carrum Downs, VIC 3201  
(+61) 0400 959 275 – info@auscompliancelab.com – www.auscompliancelab.com

**Table of revisions**

Report ID	Date issued	Details of the change
ACL1349	25/03/2022	Original issue.

**End of report**